

QUICK START GUIDE FOR YOUR



1. GROUND CONNECTION

Ground the controller's "Earth Ground" terminal to a cold water pipe or to a 4-foot ground rod to preserve its built-in transient protection. Grounding method must be in accordance with the National Electric Code, ANSI/NFPA 70.

2. TRANSFORMER CONNECTION

Connect a 24 volt 40 VA transformer to the 24VAC Input (2nd & 3rd input) in the left corner of the first terminal strip.

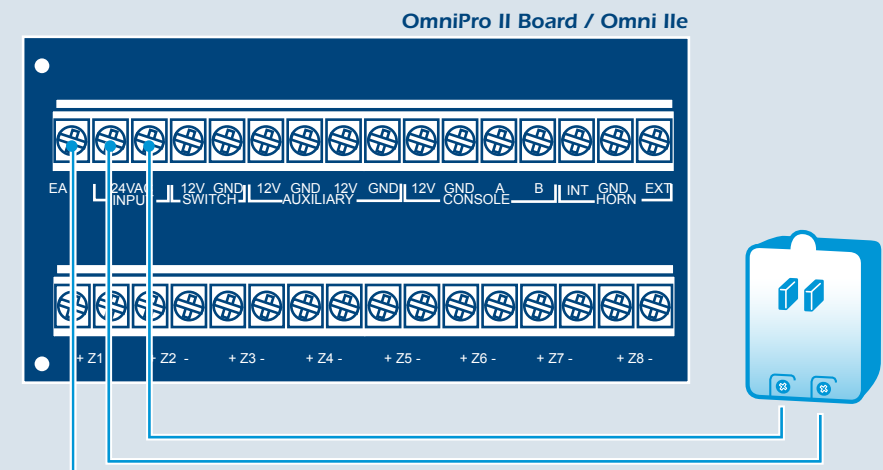

- NOTES:**
- a.) Do not plug in transformer until all devices are wired to controller.
 - b.) Be sure you connect wires to inputs 2 & 3. Do not connect transformer to the first input (Ground).
 - c.) Make sure transformer is not plugged into a switched outlet.

3. BATTERY HOOK-UP

Connect the BLACK battery wire to the minus (-) battery terminal and connect the RED battery wire to the plus (+) battery terminal of a 12 volt battery.

*** DO NOT reverse the connections.**

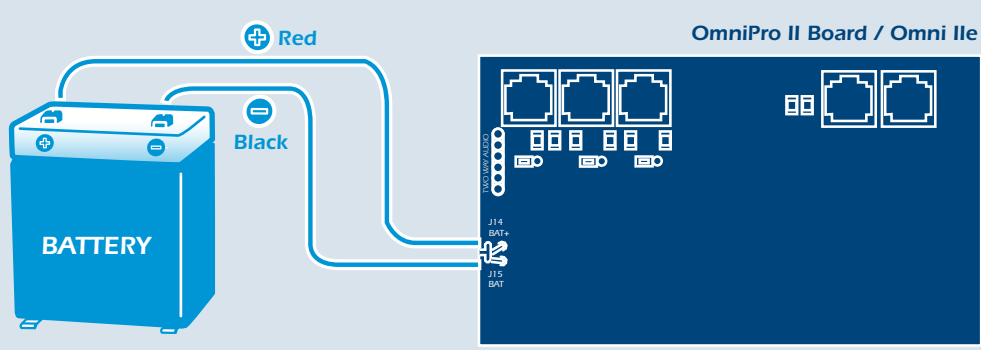

4. CONSOLE

Use 4-conductor 22 gauge wire. Consoles can be home run or daisy chained. Maximum length of wire = 1,000 feet divided by the total number of consoles on the run.

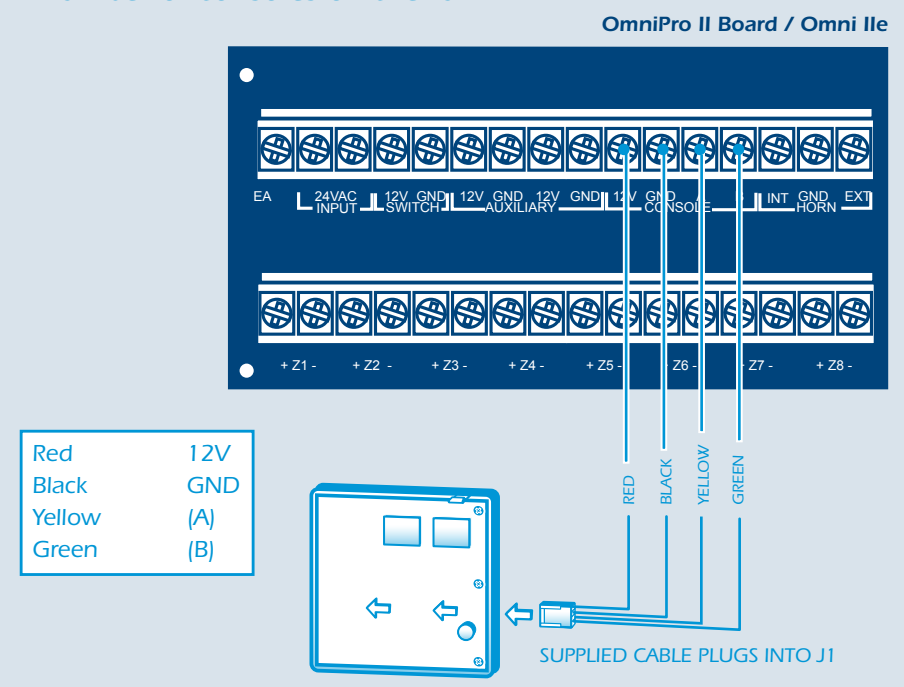

Maximum current draw from Auxiliary and Console terminal is 1A. Be sure to add total current draw from all power devices. See current draw listings below for consoles:
Omni Console- 33A00-1 = 40mA – 100mA (active)

5. PHONE CONNECTION

Connect the Green and Red wires to the incoming line. The Brown and Grey wires return to the house phones. Connect a RJ31X jack as shown in the following diagram.

NOTE: Make sure all house phones come after controller.

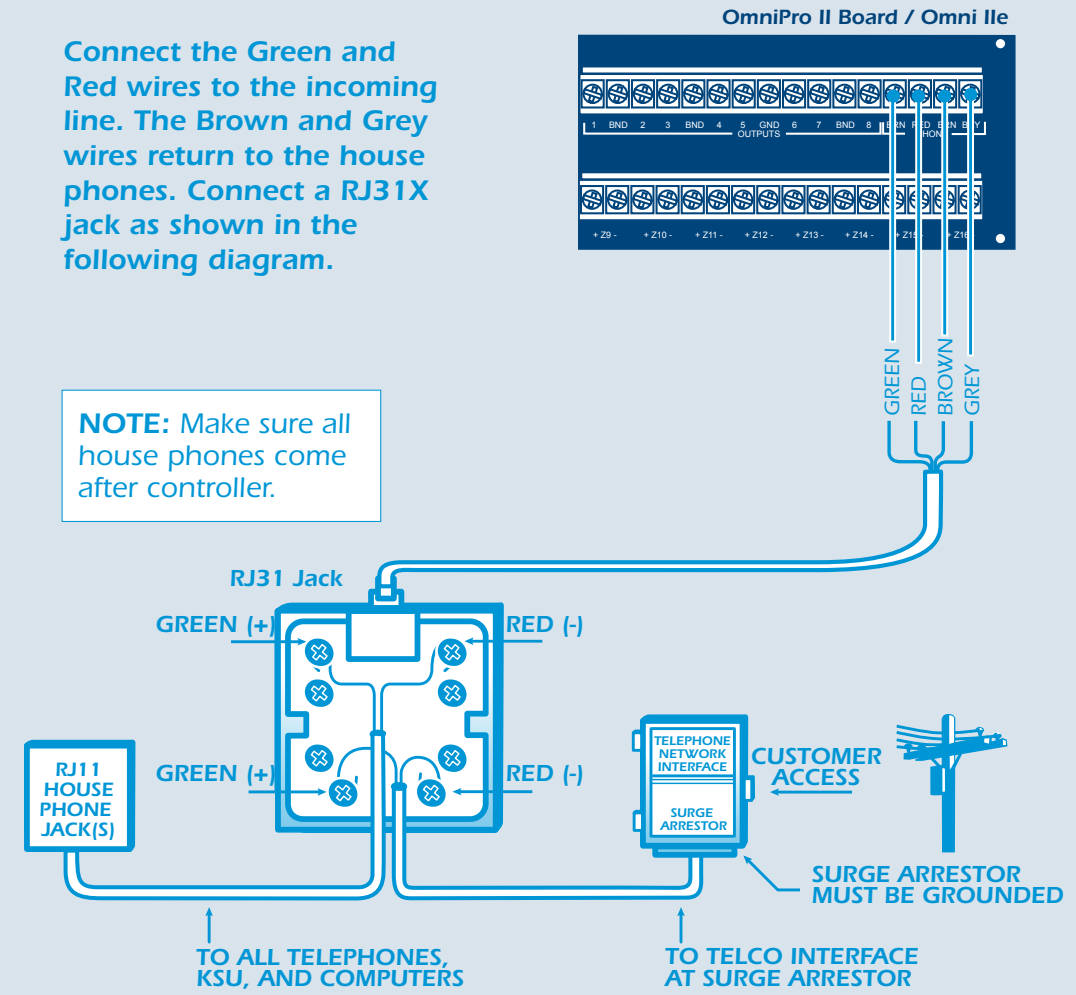

OmniPro II Board / Omni IIe Board

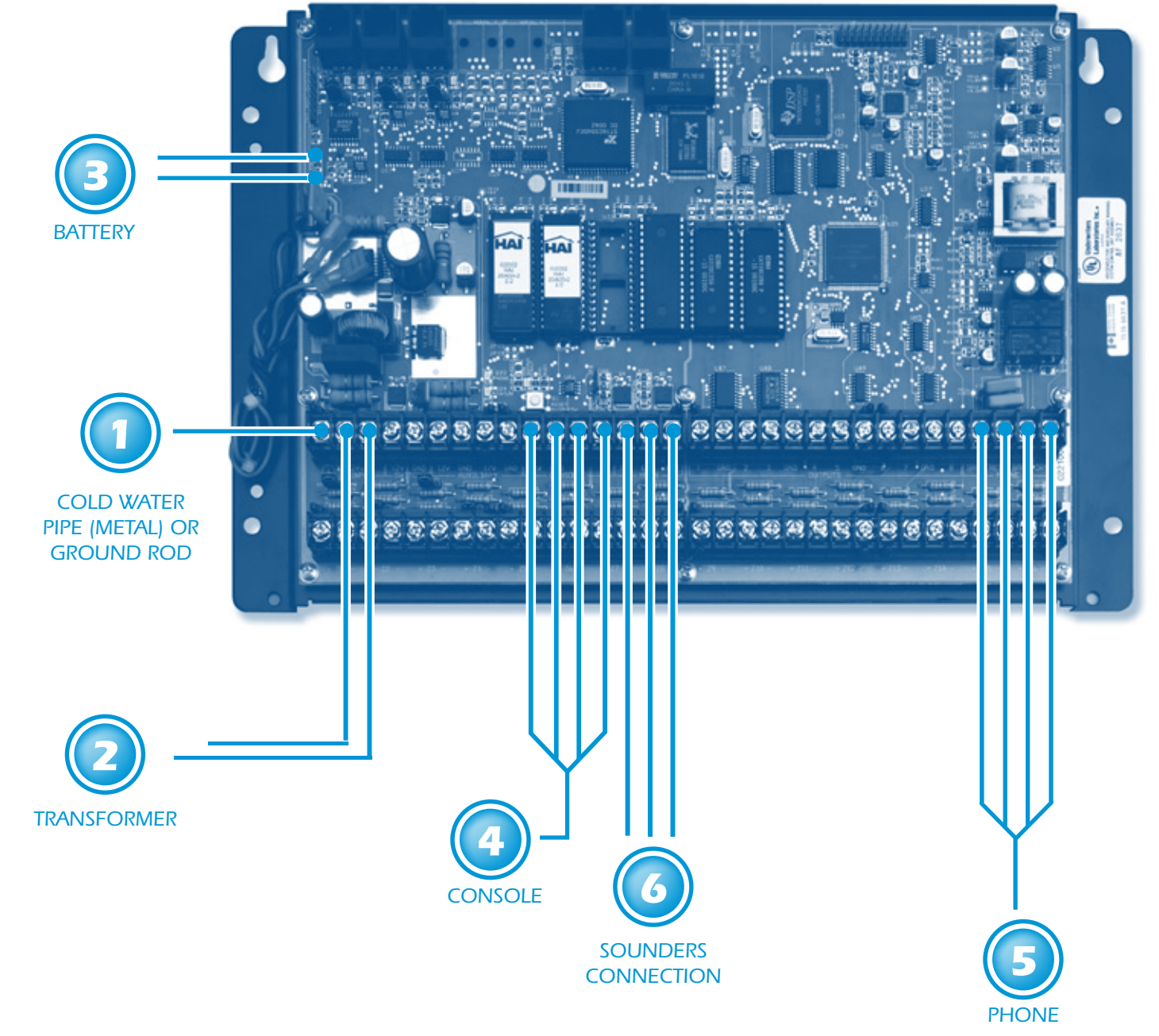

6. SOUNDERS CONNECTION

- Sounders can draw up to 1 amp MAXIMUM split between the Interior and Exterior Horn outputs.
- Use a relay connected to an auxiliary power supply if a higher current draw is required.
- If there is a slight hum coming from the siren, or if a siren is not being used, strap bell outputs out with a 1 K ohm 1/2 watt resistor.

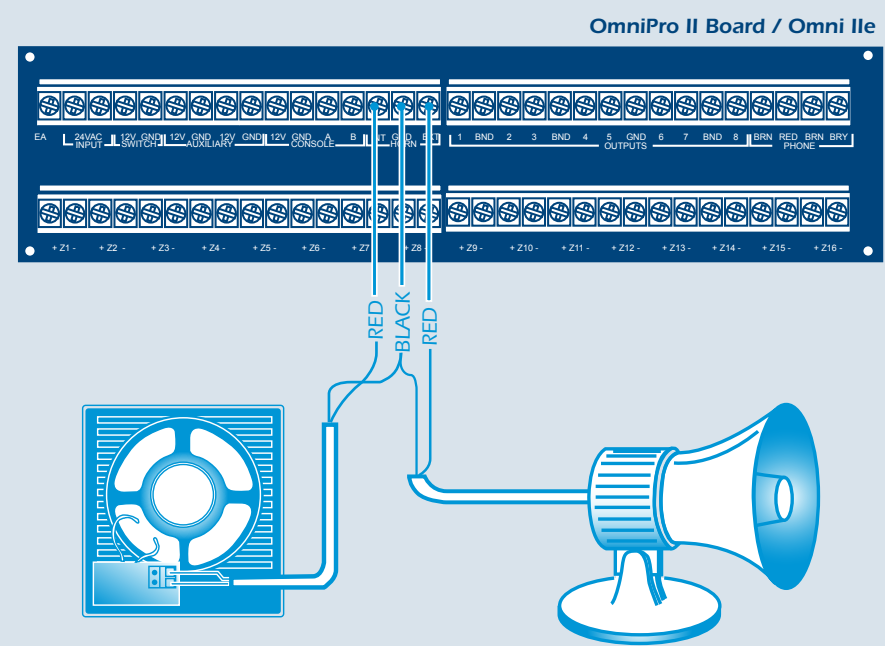

7. TWO WIRE SMOKE CONNECTION

- All two wire smoke detectors must be daisy chained (in parallel), with the 1K ohm EOL resistor at the last detector.
- Be sure to move the corresponding jumper to SMK position.
- All two wire smoke detectors must be wired to zones 1-4 only.

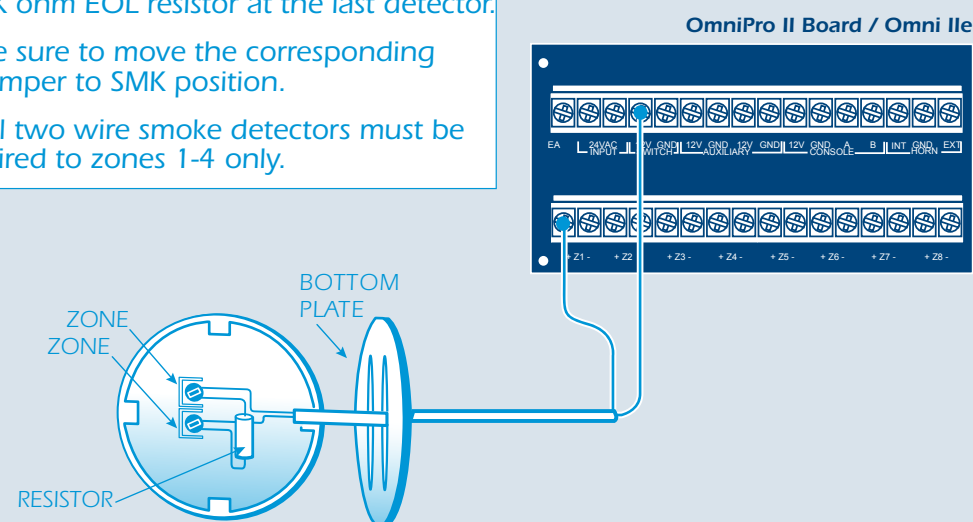

(See installation manual for complete details)

8. FOUR WIRE SMOKE CONNECTION

If multiple 4 wire smoke detectors are connected to the same zone, they must be daisy chained (in parallel), with the 1K ohm EOL resistor at the last detector. 4 wire smoke detectors may be connected to any zone. A Power Supervision Relay is required for each 4 wire zone.

(See installation manual for complete details)

9. OMNISTAT THERMOSTAT CONNECTION

- Run a 3 or 4 conductor wire from the controller to the Omnistat.
- All Omnistats are connected to Zone 16 and Output 8 on the controller.
- Make sure the black and red wires are securely connected to each other. If they are not, you will have communication problems.
- Give each Omnistat a unique address.
- Under Setup/Installer/Temps in the controller programming, enable thermostats being used.
- Disable Internal thermostat programming in thermostat (Item 03 - Display Options).

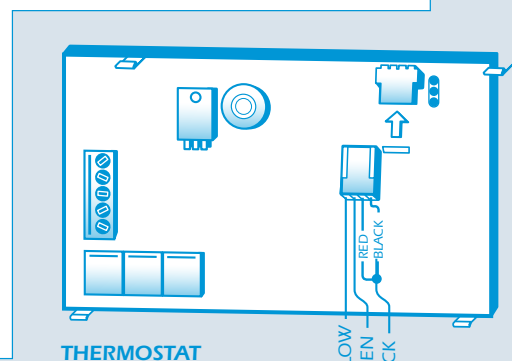

OmniPro II Board / Omni IIe

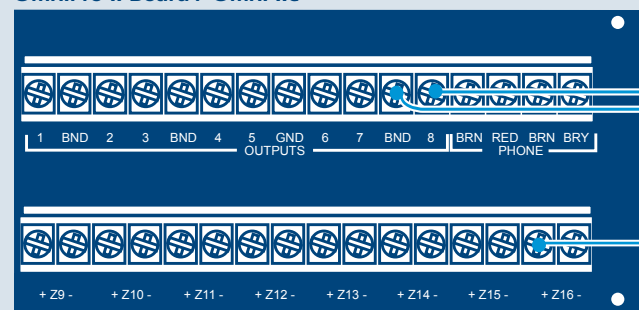

10. HARDWARE EXPANDER 10A06-1

When adding an expansion board, secure the supplied standoffs and connect them using the supplied ribbon cable. To add more than one daughter board, connect to J2 and address board using address jumper JP1.

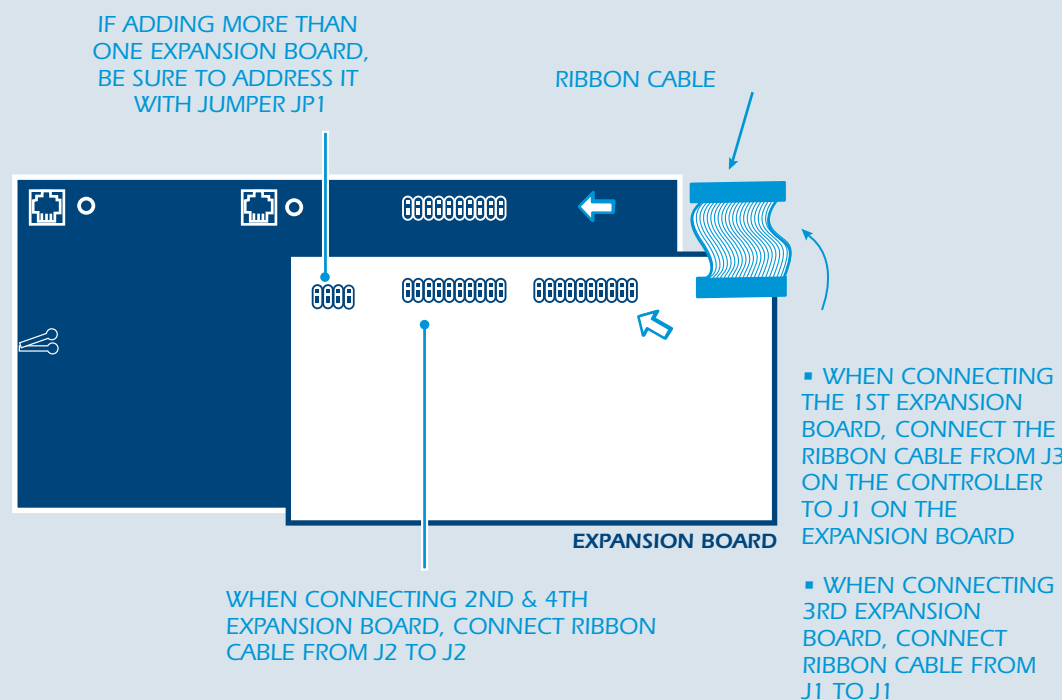

- IF ADDING MORE THAN ONE EXPANSION BOARD, BE SURE TO ADDRESS IT WITH JUMPER JP1
- WHEN CONNECTING THE 1ST EXPANSION BOARD, CONNECT THE RIBBON CABLE FROM J3 ON THE CONTROLLER TO J1 ON THE EXPANSION BOARD
- WHEN CONNECTING 2ND & 4TH EXPANSION BOARD, CONNECT RIBBON CABLE FROM J2 TO J2
- WHEN CONNECTING 3RD EXPANSION BOARD, CONNECT RIBBON CABLE FROM J1 TO J1

11. TWO-WAY VOICE MODULE

When connecting the Two-Way Voice Module to a controller, route the cable to the left side of the controller into "J9".

Mount Two-Way Voice Module to side of can using double stick tape.

- * Make sure red wire on cable faces the top of the connector.
- * Make sure that the connector is aligned with the pins on "J9".

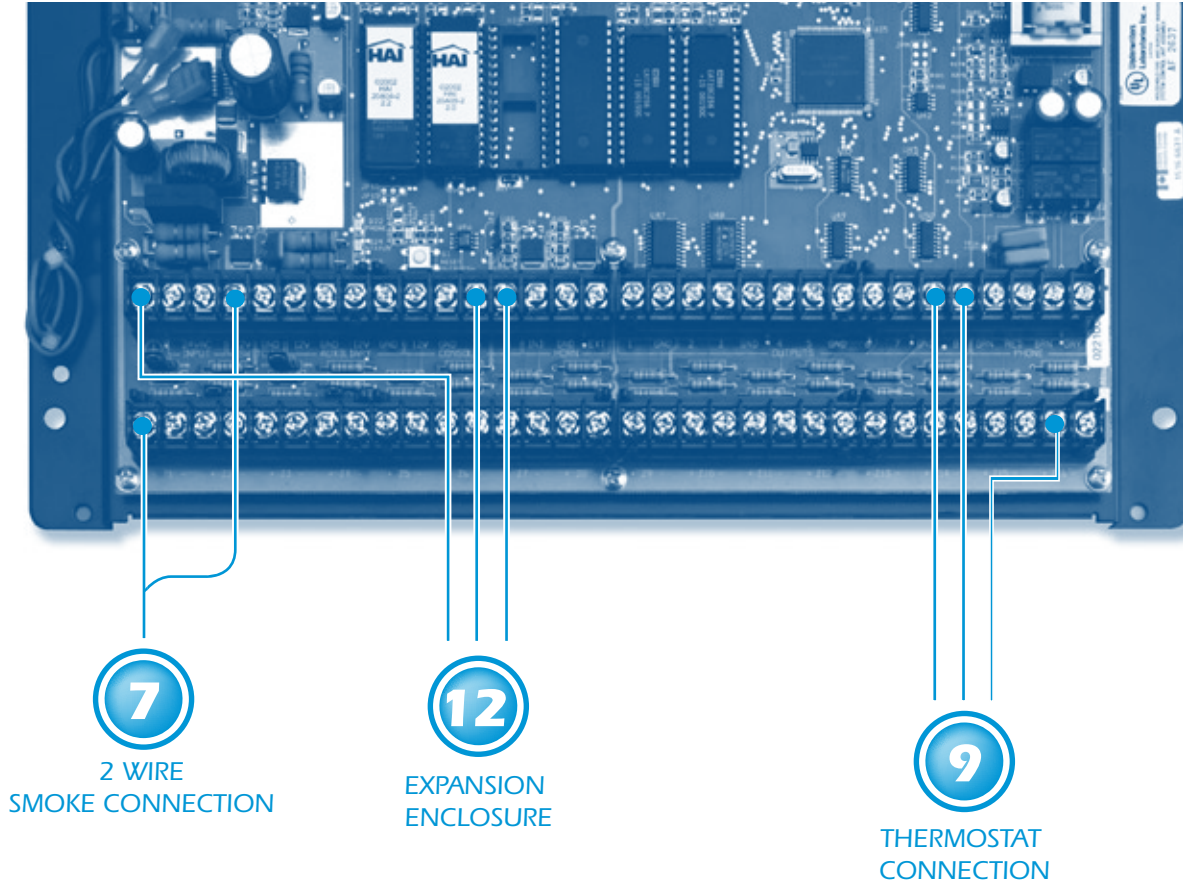
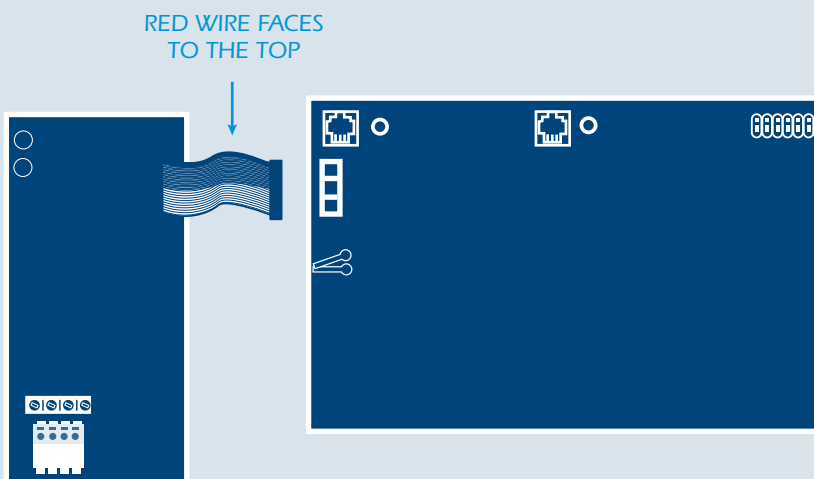

12. 17A00-1 EXPANSION ENCLOSURE (OmniPro II only)

- The Expansion Enclosure communicates with the controller using the same wires that connect the consoles to the controller.
- The communications wires for the Expansion Enclosure and consoles may be home run to the controller or daisy-chained to each other.
- Connect the terminals marked "A" and "B" on the Expansion Enclosure to the corresponding terminals on the controller or console.
- The Expansion Enclosure may be located up to 1000 feet away from the controller.
- A common ground wire must be wired to the controller.

